

MAP-400

Introduction

The Ecumaster 400 kPa MAP (Manifold Absolute Pressure) sensor is an automotive-grade pressure sensor that is not only cost-effective but also delivers precise performance. It functions by converting absolute pressure into an electrical voltage signal.



This versatile sensor can accurately measure a range of pressures, from vacuum conditions to "boost" pressures up to 300 kPa gauge, making it an ideal choice for various automotive applications.

Note: Please note that for the proper installation and best performance of the Ecumaster 400 kPa MAP sensor, it's recommended to follow all guidelines provided in the Installation.

Installation

The Ecumaster 400 kPa MAP sensor features three terminals: +5V (1), MAP out (2), and Ground (3). For proper connection, the Ground terminal (3) should be linked to the ECU sensor ground. Descriptions for each of the terminals are stamped on the sensor housing for easy identification. Ensure that the MAP sensor is securely connected to the inlet manifold using a short vacuum hose (6mm nipple diameter).

The sensor should always be installed above the intake manifold level, with the nipple facing downwards. This positioning helps protect it against the accumulation of fluids like fuel and oil that can collect in the manifold.

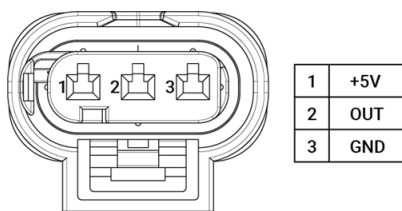

Transfer function

The transfer function, or the relationship between the output voltage (V_{out}) and the pressure (P) in kPa, is as follows:

$$V_{out} = 5.0 * (0.002421 * P - 0.00842)$$

Here, V_{out} represents the sensor's output voltage, and P refers to the measured pressure in kPa. With this transfer function, you can calculate the sensor output for any

given pressure value, aiding in the accurate interpretation of sensor readings.

Pressure (kPa)	20	100	200	300	400
Voltage (V)	0.20	1.17	2.38	3.59	4.80

Dimensions

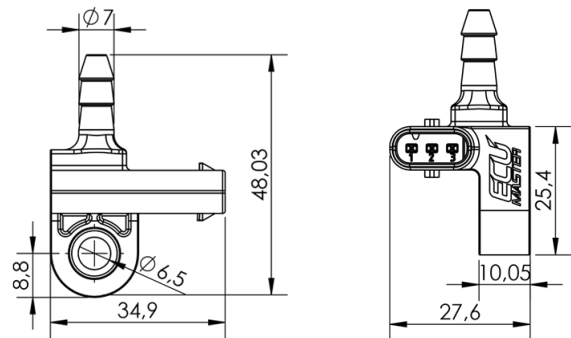

Connector and terminals

Connector part number: 1-1670917-1

Terminals part number: 7-1452656-3

Characteristics

General	
Supply voltage	5.0 V
Supply current	< 10 mA
Pressure range	20 to 400 kPa
Full scale span	4.6 V
Sensitivity	12.1 mV/ kPa
Operating temperature	-25 °C to 125 °C
Accuracy	+/- 1.5%
Enclosure	PA6-GF15 plastic mold, IP67
Absolute maximum ratings	
Maximum pressure	1600 kPa (232 psi)
Maximum supply voltage	5.5 V
Maximum load current	+/- 0.5 mA

Warning: Ecumaster 400 kPa MAP sensor is not designed for use with fluids!